

AMG-L

Low - speed granulator

低速机边粉碎机系列



▶ AMG-300L

Description:

AMG-L Series Beside-the-Press Granulators are installed beside injection molding machine, feeding by Robot or manpower, to crush small stub bar. The machine works to reduce the the material waste and pollution, and increase the material availability to save manpaower and production cost.

AMG-L机边立即回收粉碎机，将此机器安装在机台旁，配以机械手（也可以人工投料回收），可将小型水口料立即粉碎并按一定比例与新料混合使用，既减少原料的浪费，又减轻了原料的污染源，提高了原料的利用率。更可节省人力资源，降低企业成本。

Close-up 特写



▶ AMG-L Claw Blades

机器特点

- 小功率，低噪音，特别适合于无尘静音车间；
- 直接传动，传动效率特高（0.97-0.995），粉碎能力更强，更节省能源；
- 动刀具特殊设计，刃磨后不需调节刀具间隙，更方便拆卸，更换；
- 定刀具设计为4刃,可使用4次后才刃磨，减少刃磨次数,持久耐用；
- 进料斗与接料盒有安全装置，使用安全；
- 电机设过负荷保护，保护电机安全；
- 安装脚轮，移动方便。

Machine Features:

- Low power and low noise, suitable to quiet and dust-free workshop;
- Direct transmission with high efficiency (0.97-0.995), works with high capacity and energy-saving;
- Special designed rotating blades, no need to adjust gap after resharpening, easy to install and change blades;
- 4-edges designed fixed blades need to be resharpened after 4 times using;
- Protection device fixed on inlet hopper and material drawer, works safely;
- Overload device to protect motor;
- Fixed with castor, easily to move.

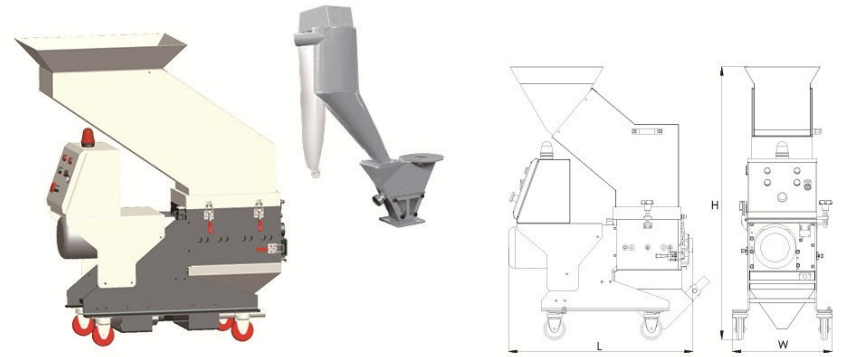

▶ AMG-400L

Specifications 规格表

机型 Model	低速机边粉碎机 Low-speed granulator				
	AMG-200L	AMG-300L	AMG-350L	AMG-400L	
电机功率 Power	kw	1.1	1.5	3.0	3.0
主轴转速 Rotor speed	rpm	150	150	150	150
转动刀 Rotating blades	pcs	21	30	36	42
固定刀 Fixed blades	pcs	2	2	2	4
筛网孔径 Screen Diameter	mm	φ 6	φ 6	φ 6	φ 6
粉碎室尺寸 Cutting Chamber Size	mm	270 × 200	270 × 300	295 × 350	295 × 400
粉碎能力 Output	kg/h	30 - 60	50 - 80	80 - 120	100 - 150
粉碎时噪音 Noise	dB(A)	80 - 85	80 - 85	80 - 85	80 - 85
风机送料系统 Blower Conveying System		●	●	●	●
立即回收系统 Instantaneous recycling system		●	●	●	●
比例阀送料装置 Proportional-valve Conveying Device		○	○	○	○
人工接料箱 Material Box		○	○	○	○
重量 Weight	kg	150	165	200	220
外形尺寸 (主机尺寸) External size					
L	mm	790	880	1100	1190
W	mm	480	480	500	500
H	mm	1350	1350	1350	1350

产品规格若有变更,恕不另行通知。Please excuse for not note if some specifications of products are changed.

Note 注:

- 1) ●为标配, ○为选购。
- 2) The max. shredding quantity depend on the mesh holediameter and shredding material quality.
- 3) The varied noise depend on varied shredding material.
- 4) The machine voltage specification is 3∅,380V,50Hz. The voltage can be changed as you require.

- 1) ●为标配, ○为选购。
- 2) 最大粉碎量取决于筛网孔径及粉碎材料等因素。
- 3) 粉碎时噪音因粉碎材料不同而各异。
- 4) 机器电压规格3∅,380V,50Hz。